

上海博众测量技术有限公司

Bodhi (Shanghai) measurement technology Co.,Ltd.
NO.32,ShuPing Road, JiadingDistrict,ZIP201808,
Shanghai R.P.China

TEL: 0086 21 6630 8161/62/63

FAX: 0086 21 6630 8167

USER'S GUIDE

Vaisala Humidity and Temperature Probes HMP60 and HMP110 Series



Table of Contents

CHAPTER 1	
GENERAL INFORMATION	5
About This Manual	5
Contents of This Manual	5
Version Information	6
Related Manuals	6
Documentation Conventions	6
Safety	7
ESD Protection	7
Recycling	8
Regulatory Compliances	8
Trademarks	9
License Agreement	9
Warranty	9
CHAPTER 2	
PRODUCT OVERVIEW	10
Introduction to HMP60 and HMP110 Series	10
Basic Features and Options	12
Filter Options	13
Installation Accessories (Optional)	14
Probe Mounting Clamp	14
Probe Mounting Flange	16
Plastic Locking Bushing for HMP63 and HMP113	16
Duct Installation Kit for HMP60, HMP110, HMP110D and HMP110T	17
Loop Power Converter	18
Cables	19
CHAPTER 3	
INSTALLATION	20
Dimensions for HMP60, HMP110, HMP110D and HMP110T	20
Dimensions for HMP63 and HMP113	21
Mounting the HMP60, HMP110, HMP110D and HMP110T Probes	22
Probe Assembly with Duct Installation Kit	22
Drilling Instructions for Duct Installation Kit	23
Mounting the HMP63 and HMP113 Probes	24
Wiring	25
Wiring with the Loop Power Converter	27
Power Supply Requirements	28
Recommendations	28
CHAPTER 4	

OPERATION	29
Getting Started	29
Serial Line Communication	29
Connecting to the Serial Interface	30
Installing the Driver for the USB Cable	31
Terminal Application Settings for Digital Probes	32
Accessing Serial Line Command Interface (RS-485 Mode) from Analog or Modbus Mode	34
Modbus Communication	35
List of Serial Commands	36
Device Information and Status	37
View Device Information	37
View Calibration Information	38
Enter Calibration Information	38
View Order Code	38
View Serial Number	39
View Software Version	39
Serial Line Output Commands	39
Start Measurement Output	39
Stop Measurement Output	40
Output the Measurement Message Once	40
Configuring Serial Line Operation	40
Set Serial Line Settings	40
Set Serial Interface Mode	41
Set Output Interval	42
Set Measurement Filtering	42
Set Probe Address	43
Set Serial Interface Delay	43
Set Measurement Units	44
Calibration Commands	45
Calibrate Humidity Measurement	45
Clear Adjustment of RH Measurement	46
Calibrate Temperature Measurement	46
Clear Adjustment of T Measurement	47
View User Adjustment Parameters	47
Other Commands	48
Set Analog Output Mode	48
Set Analog Output Parameters and Scaling	49
Set Analog Output Error Indication Level	50
Extend Analog Output Range	51
Extend Maximum RH Reading	51
Display Command List	52
Display the Currently Active Errors	52
Connect to the Probe in POLL Mode	52
Close the Connection in POLL Mode	53
Reset the Probe	53
Restore Factory Settings	53
 CHAPTER 5	
MAINTENANCE	54
Periodic Maintenance	54
Cleaning	54
Changing the Filter	54
Calibration Procedure	55

Adjustment Procedure Using Serial Line (HMP110, HMP110D and HMP113)	56
One-Point Adjustment of RH Measurement (HMP110, HMP110D and HMP113)	56
Two-Point Adjustment of RH Measurement (HMP110, HMP110D and HMP113)	57
One-Point Adjustment of T Measurement (HMP110, HMP110D, HMP113, and HMP110T)	59
Adjustment Procedure Using MI70 Indicator (HMP110, HMP110D and HMP113)	60
One-Point Adjustment of RH Measurement (HMP110, HMP110D and HMP113)	60
One-Point Adjustment of Temperature Measurement	61
Repair Maintenance	63
Changing the INTERCAP® Sensor (HMP60 and HMP63)	63
Changing the HUMICAP® 180R Sensor (HMP110, HMP110D and HMP113)	64
 CHAPTER 6	
TROUBLESHOOTING	65
Analog Output Error Notification	65
Solving Typical Problems	65
Technical Support	66
 CHAPTER 7	
TECHNICAL DATA	67
Specifications	67
Performance (HMP60 and HMP63)	67
Relative Humidity	67
Temperature	67
Dewpoint	67
Performance (HMP110 and HMP110D)	68
Relative Humidity	68
Temperature	68
Dewpoint	68
Performance (HMP113)	69
Relative Humidity	69
Temperature	69
Dewpoint	69
Performance (HMP110T)	69
Temperature	69
Operating Environment	70
Inputs and Outputs	70
Mechanics (HMP60, HMP110, HMP110D and HMP110T)	71
Mechanics (HMP63 and HMP113)	71
Options and Accessories	72
 APPENDIX A	
MODBUS REFERENCE	73
Supported Modbus Functions	73
Modbus Register Map	74
Device Identification Objects	76
Communication Test Registers	76

List of Figures

Figure 1	HMP60 and HMP110 Series Probes	11
Figure 2	Filters for HMP60, HMP110, HMP110D, and HMP110T	13
Figure 3	Filters for HMP63 and HMP113	13
Figure 4	Probe Mounting Clamp in Use	14
Figure 5	Aligning Mounting Clamp Slots	14
Figure 6	Sliding the Lower Clamp Part	15
Figure 7	Securing the Upper Clamp Part	15
Figure 8	Probe Mounting Flange	16
Figure 9	HMP113 with Plastic Locking Bushing	16
Figure 10	Probe Installation with the Duct Installation Kit	17
Figure 11	Loop Power Converter	18
Figure 12	Cable with Threaded Connector	19
Figure 13	USB Serial Interface Cable	19
Figure 14	HMP60, HMP110, HMP110D, and HMP110T Dimensions	20
Figure 15	Installation with Plastic M12 Nuts, Dimensions	20
Figure 16	HMP63 and HMP113 Dimensions	21
Figure 17	HMP63 and HMP113 with Plastic Locking Bushing, Dimensions	21
Figure 18	Assembly of the Probe with Duct Installation Kit	22
Figure 19	Drilling Instructions	23
Figure 20	Wiring of Analog Output	25
Figure 21	Wiring of Digital Output	25
Figure 22	Wiring with the Loop Power Converter Module	27
Figure 23	PuTTY Terminal Application	33
Figure 24	INTERCAP® Sensor	63
Figure 25	Removing the Sensor	63
Figure 26	HUMICAP® 180R Sensor	64

List of Tables

Table 1	Manual Revisions	6
Table 2	Related Manuals	6
Table 3	Parameters Measured by HMP60 and HMP110 Series	10
Table 4	Grounding Methods	25
Table 5	Pinout of the Probe Connector	26
Table 6	Operating Voltage Ranges	28
Table 7	Default Serial Communication Settings	30
Table 8	Default Modbus Communication Settings	35
Table 9	Configuration Commands for Modbus RTU	35
Table 10	List of Serial Commands (software version 2.0.7)	36
Table 11	Additional Commands for Probes with RS-485 Output	37
Table 12	Serial Interface Modes	41
Table 13	Troubleshooting Table	65
Table 14	Options and Accessories	72
Table 15	Connection Cables	72
Table 16	Supported Function Codes	73
Table 17	Modbus Register Map (Measurement Values and Settings)	74
Table 18	Device Identification Objects	76
Table 19	Communication Test Registers	76

CHAPTER 1

GENERAL INFORMATION

This chapter provides general notes for the manual and the HMP60 and HMP110 series probes.

About This Manual

This manual provides information for installing, operating, and maintaining HMP60 and HMP110 series probes.

Contents of This Manual

This manual consists of the following chapters:

- Chapter 1, General Information, provides general notes for the manual and the HMP60 and HMP110 series probes.
- Chapter 2, Product Overview, introduces the features and options of the HMP60 and HMP110 series probes.
- Chapter 3, Installation, provides you with information that is intended to help you install the HMP60 and HMP110 series probes.
- Chapter 4, Operation, contains information that is needed to operate the HMP60 and HMP110 series probes.
- Chapter 5, Maintenance, provides information that is needed in basic maintenance of the HMP60 and HMP110 series probes.
- Chapter 6, Troubleshooting, describes common problems, their probable causes and remedies, and contact information for technical support.
- Chapter 7, Technical Data, provides the technical data of the HMP60 and HMP110 series probes.

Version Information

Table 1 Manual Revisions

Manual Code	Description
M211060EN-G	January 2016. This manual. Modbus protocol added. Updated instructions for switching the probe to serial mode from analog or Modbus mode. Relative humidity factory calibration uncertainty specification updated. Added information about using HMP110 with an MI70 indicator when in analog mode. Added instructions for entering calibration information with the CDATE and CTEXT commands.
M211060EN-F	March 2015. Previous version. Applicable to software version 2.0.7. Added new probe type HMP110D. Updated technical specification, updated options and accessories. Added AERR and RHLIMIT serial line commands, removed the ADJD command. Added adjustment instructions for MI70 indicator. Added a new error code.
M211060EN-E	January 2013. Previous version. Updated description of SMODE command.

Related Manuals

Table 2 Related Manuals

Manual Code	Manual Name
M211059EN	HMP60 and HMP110 Series Multilingual Quick Guide
M211106EN	Loop Power Converter Quick Reference Guide
M211080EN	Mounting Flange for Humidity Probes Quick Reference Guide

Documentation Conventions

Throughout the manual, important safety considerations are highlighted as follows:

WARNING

Warning alerts you to a serious hazard. If you do not read and follow instructions very carefully at this point, there is a risk of injury or even death.

CAUTION Caution warns you of a potential hazard. If you do not read and follow instructions carefully at this point, the product could be damaged or important data could be lost.

NOTE Note highlights important information on using the product.

Safety

The product delivered to you has been tested for safety and approved as shipped from the factory. Note the following precautions:

CAUTION Do not modify the unit. Improper modification can damage the product or lead to malfunction.

NOTE Before you connect an HMP60 or HMP110 series probe to a device, it is recommended to power off the device.

ESD Protection

Electrostatic Discharge (ESD) can cause immediate or latent damage to electronic circuits. Vaisala products are adequately protected against ESD for their intended use. It is possible to damage the product, however, by delivering electrostatic discharges when touching, removing, or inserting any objects inside the equipment housing.

To make sure you are not delivering high static voltages yourself:

- Handle ESD sensitive components on a properly grounded and protected ESD workbench.
- When an ESD workbench is not available, ground yourself to the equipment chassis with a wrist strap and a resistive connection cord.
- If you are unable to take either of the above precautions, touch a conductive part of the equipment chassis with your other hand before touching ESD sensitive components.
- Always hold component boards by the edges and avoid touching the component contacts.

Recycling



Recycle all applicable material.



Do not dispose of with regular household refuse.

Regulatory Compliances

HMP60 and HMP110 series probes are in conformity with the provisions of the following EU directive(s):

ROHS Directive
EMC Directive

The electromagnetic compatibility of HMP60, HMP110, HMP110D and HMP110T and HMP110REF has been tested according to the following product family standards:

- EN 61326-1: Electrical equipment for measurement, control and laboratory use - EMC requirements – for use in industrial locations.
- EN 55022 Class B: Information technology equipment - Radio disturbance characteristics - Limits and methods of measurement.

The electromagnetic compatibility of HMP63 and HMP113 has been tested according to the following product family standards:

- EN 61326-1: Electrical equipment for measurement, control and laboratory use - EMC requirements – Basic immunity test requirements.
- EN 55022 Class B: Information technology equipment - Radio disturbance characteristics - Limits and methods of measurement.



Trademarks

Vaisala INTERCAP® and Vaisala HUMICAP® are registered trademarks of Vaisala Oyj.

Windows® is a registered trademark of Microsoft Corporation in the United States and/or other countries.

License Agreement

All rights to any software are held by Vaisala or third parties. The customer is allowed to use the software only to the extent that is provided by the applicable supply contract or Software License Agreement.

Warranty

Please observe that any such warranty may not be valid in case of damage due to normal wear and tear, exceptional operating conditions, negligent handling or installation, or unauthorized modifications. Please see the applicable supply contract or Conditions of Sale for details of the warranty for each product.

CHAPTER 2

PRODUCT OVERVIEW

This chapter introduces the features and options of the HMP60 and HMP110 series probes.

Introduction to HMP60 and HMP110 Series

Vaisala Humidity and Temperature Probes HMP60 and HMP110 Series are simple and cost-effective humidity transmitters suitable for various volume applications:

- Integration into other manufacturers' equipment.
- Incubators.
- Glove boxes.
- Greenhouses.
- Fermentation chambers.
- Data loggers.
- Hand-held meters.

HMP60 series probes use the interchangeable Vaisala INTERCAP® sensor. No recalibration is required after sensor replacement.

HMP110 series probes use the Vaisala HUMICAP® 180R sensor for increased accuracy. HMP110 series probes require calibration after sensor replacement. This can be done on the serial line using the optional Vaisala USB cable.

Table 3 Parameters Measured by HMP60 and HMP110 Series

Parameter	Abbreviation	Metric Unit	Non Metric Unit
Relative humidity	RH	%RH	%RH
Dewpoint/Frostpoint temperature*	T _{df}	°C	°F
Temperature	T	°C	°F

* When the dewpoint is below 0 °C, the probe outputs frostpoint for T_d



1210-009

Figure 1 HMP60 and HMP110 Series Probes

No.	Model	Description
1	HMP60	IP65 rated stainless steel probe with INTERCAP® sensor. Rugged probe for demanding applications. Two analog output channels.
2	HMP110	IP65 rated stainless steel probe with HUMICAP® 180R sensor. Rugged probe with higher accuracy for demanding applications. Two analog output channels.
3	HMP110D	IP65 rated stainless steel probe with HUMICAP® 180R sensor. Rugged probe with higher accuracy for demanding applications. Digital output only.
4	HMP110T	IP65 rated stainless steel probe with temperature sensor only. Has the same temperature measurement performance as HMP110. One analog output channel.
5	HMP110REF	IP65 rated stainless steel probe. Does not measure; instead, outputs constant humidity and temperature readings on serial line. Useful for validating installations of HMT120 and HMT130 transmitters, for example. Digital output only.
6	HMP63	IP54 rated probe with PC/ABS plastic housing and INTERCAP® sensor. Lightweight probe with faster thermal response time. Not for permanent outdoor use. Two analog output channels.
7	HMP113	IP54 rated probe with PC/ABS plastic housing and HUMICAP® 180R sensor. Lightweight probe with higher accuracy and faster thermal response time. Not for permanent outdoor use. Two analog output channels. Used with the Vaisala HM40 hand-held meter (requires special software configuration).

Basic Features and Options

- Analog and digital output options:
 - HMP60, HMP63, HMP110 and HMP113 analog output mode: two analog output channels, selectable from 0 ... 1 V / 0 ... 2.5 V / 0 ... 5 V / 1 ... 5 V.
 - HMP110T analog output mode: single analog output channel (CH1), selectable from 0 ... 1 V / 0 ... 2.5 V / 0 ... 5 V / 1 ... 5 V.
 - RS-485 interface available for all models (Modbus RTU and Vaisala Industrial Protocol serial line communication).
- Small size.
- Low power consumption.
- IP65 stainless steel body on HMP60 and HMP110 models.
- IP54 lightweight plastic body on HMP63 and HMP113 models.
- Options and accessories:
 - Several filter options; see section Filter Options on page 13.
 - Probe mounting clamp.
 - Probe mounting flange.
 - Duct installation kit for HMP60, HMP110, HMP110D and HMP110T.
 - One channel loop power converter 4 ... 20 mA (separate module, compatible with humidity accuracy only).
 - Shielded 0.3 m and 3.0 m connection cables with threaded connector for probe connection, open end wires on the other end.
 - Plastic M12 installation nuts for HMP60, HMP110, HMP110D and HMP110T.
 - Plastic locking bushing for HMP63 and HMP113 (for use with Vaisala products, for example HM40 hand-held meter).

Filter Options

For order codes, see section Options and Accessories on page 72.



1001-008

Figure 2 Filters for HMP60, HMP110, HMP110D, and HMP110T

No.	Filter	Diameter	Pore Size
1	Plastic grid filter (fastest response time)	12 mm	-
2	Membrane filter	12 mm	0.2 μm
3	Stainless steel sintered filter	12 mm	38 μm

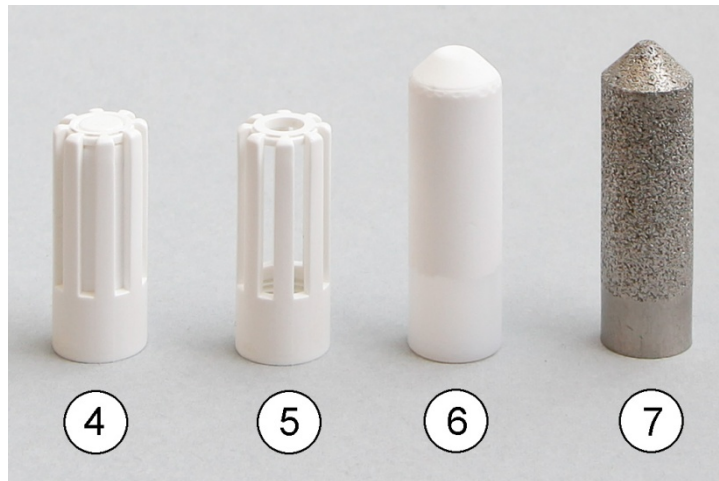

1210-010

Figure 3 Filters for HMP63 and HMP113

No.	Filter	Diameter	Pore Size
4	Plastic membrane filter	12 mm	0.2 μm
5	Plastic grid filter for (portable use only, fastest response time)	12 mm	-
6	Porous PTFE filter	12 mm	8 μm
7	Stainless steel sintered filter	12 mm	38 μm

Installation Accessories (Optional)

For order codes, see section Options and Accessories on page 72.

Probe Mounting Clamp

The optional mounting clamp makes it easy to install the probe on the wall of the measurement environment. The probe can be detached for calibration simply by loosening the lower screw.

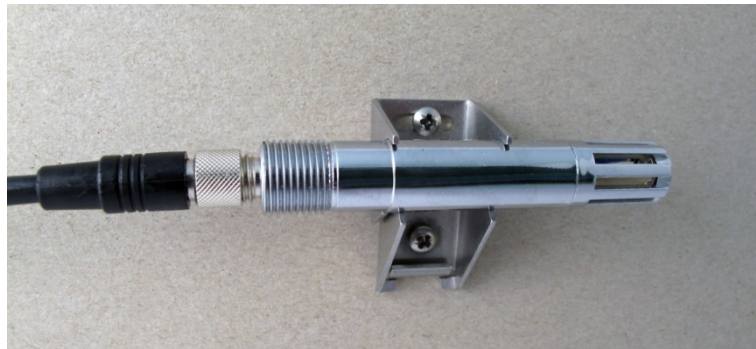

1001-138

Figure 4 Probe Mounting Clamp in Use

The probe mounting clamp is delivered in two parts that must be connected when it is used:

1. Align the slots on the clamp parts as shown in Figure 5 below.



1209-001

Figure 5 Aligning Mounting Clamp Slots

2. Slide the lower clamp part over to the bottom end of the upper part as shown in Figure 6 below.



1209-002

Figure 6 Sliding the Lower Clamp Part

3. Place the clamp to the intended location and secure the upper clamp part with a screw. See Figure 7 below.



1209-003

Figure 7 Securing the Upper Clamp Part

4. Place the probe in the clamp.
5. Tighten the lower clamp part with a screw.

Probe Mounting Flange

The probe mounting flange is a silicone flange that can be used to hold the probe in a through-wall installation. The flange is a general purpose mounting accessory for Ø 12mm probes, and comes with a sealing plug for coaxial cables that is not needed when the flange is used with HMP60 and HMP110 series probes.



0911-109

Figure 8 Probe Mounting Flange

Plastic Locking Bushing for HMP63 and HMP113

HMP63 and HMP113 can be connected to compatible Vaisala instruments using a plastic locking bushing that is placed over the probe. The bushing has a M15x1 thread. It is compatible with the HMT120 and HMT130 transmitters, and the HM40 hand-held meter.



1210-029

Figure 9 HMP113 with Plastic Locking Bushing

Duct Installation Kit for HMP60, HMP110, HMP110D and HMP110T

The duct installation kit includes a plastic pipe with a flange (Vaisala order code: 215619). To install the probe with the duct installation kit, drill a hole to the duct wall, assemble the probe to the duct installation kit, slide the probe head through the hole, and attach the flange to the duct wall with four screws. See page 22 for details.

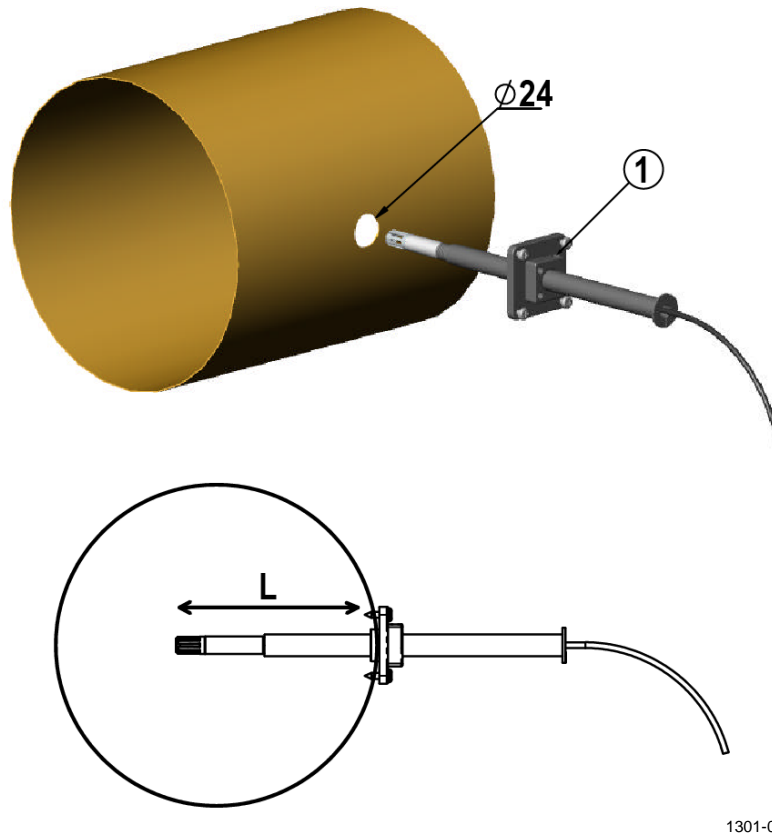

Figure 10 Probe Installation with the Duct Installation Kit

The following explanations refer to Figure 10 above:

1 = Tension screw

Distance L can be adjusted and locked in place with the tension screw.

Loop Power Converter

The loop power converter is an open frame module that converts one 0 ... 2.5 VDC voltage output to a 4 ... 20 mA current output. To use the loop power converter module, the probe:

- must be in the analog output mode
- the desired quantity is on channel 1
- channel 1 must be scaled to 0 ... 2.5 V

Wiring instructions are provided in section Wiring with the Loop Power Converter on page 26.

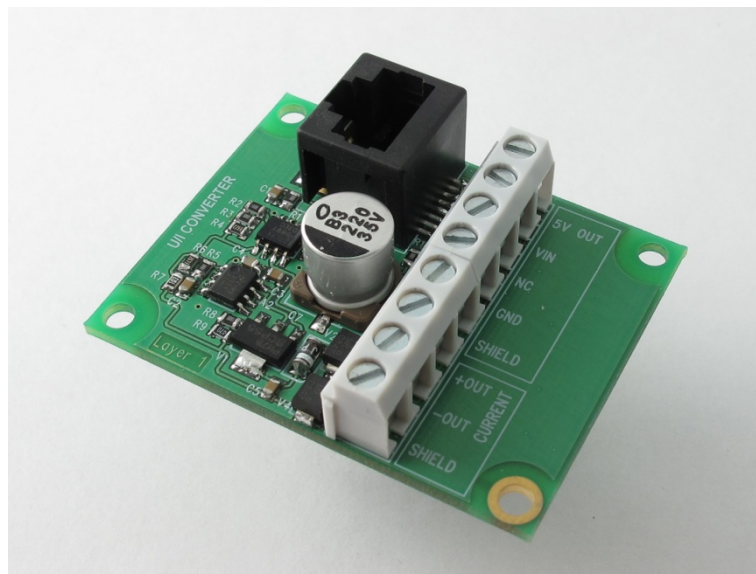

1001-001

Figure 11 **Loop Power Converter**

Cables

Connection cables have a straight, threaded female M8 connector on one end and open wires on the other end. Also other compatible M8 series cables can be used.



1210-063

Figure 12 Cable with Threaded Connector

The USB Serial Interface Cable has a straight, threaded female M8 connector on one end, and a USB Type A male plug on the other. The USB cable is intended for maintenance purposes only, not for permanent installation.



1210-062

Figure 13 USB Serial Interface Cable

CHAPTER 3

INSTALLATION

This chapter provides you with information that is intended to help you install the HMP60 and HMP110 series probes.

NOTE

Before you connect an HMP60 or HMP110 series probe to a device, it is recommended to power off the device.

Dimensions for HMP60, HMP110, HMP110D and HMP110T

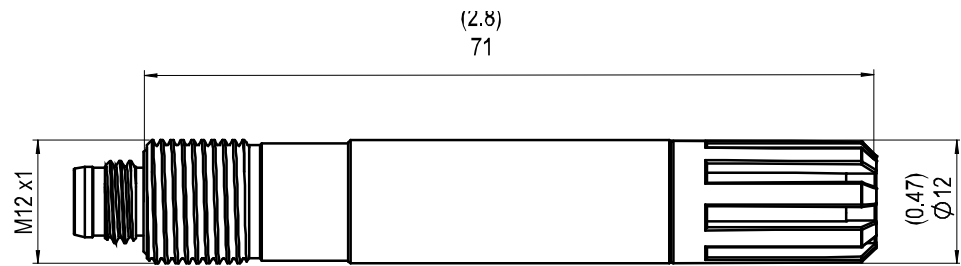

0912-103

Figure 14 HMP60, HMP110, HMP110D, and HMP110T Dimensions

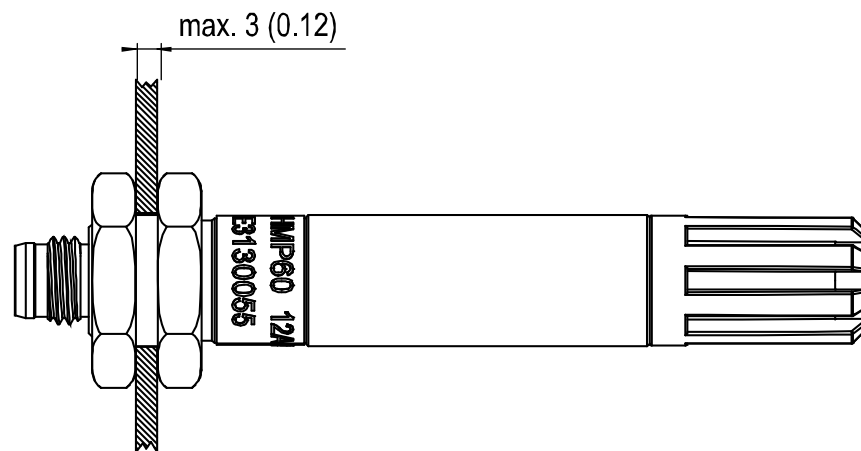

0912-102

Figure 15 Installation with Plastic M12 Nuts, Dimensions

Dimensions for HMP63 and HMP113

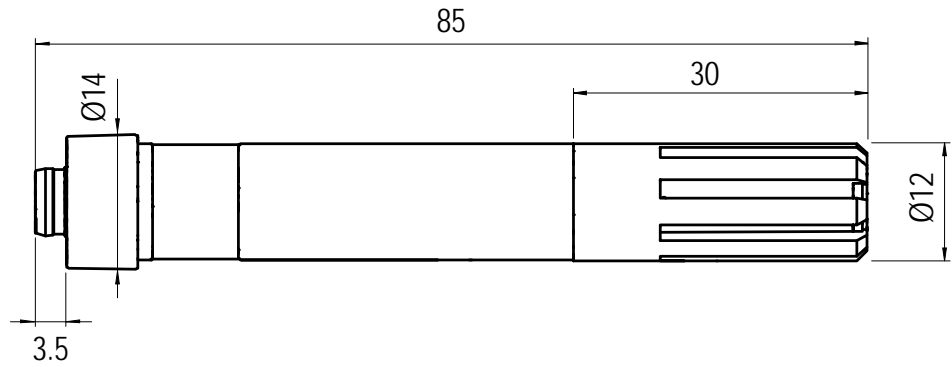

0912-103

Figure 16 HMP63 and HMP113 Dimensions

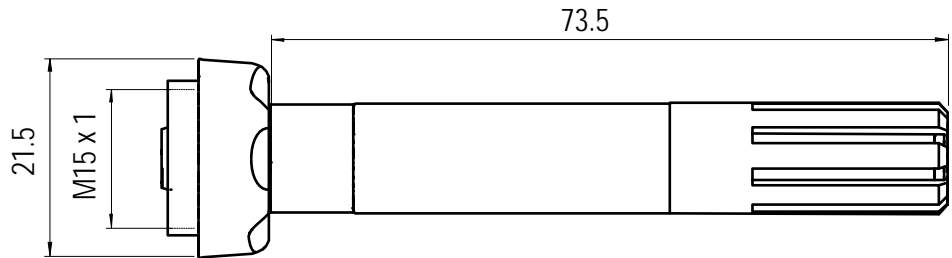

0912-102

Figure 17 HMP63 and HMP113 with Plastic Locking Bushing, Dimensions

Mounting the HMP60, HMP110, HMP110D and HMP110T Probes

HMP60, HMP110, HMP110D and HMP110T are designed to be mounted from the M12 thread on the probe body or from the smooth part of the probe body. For a convenient installation, use the optional installation accessories:

- Use the plastic mounting nuts to hold the probe in a through-wall installation.
- Use the probe mounting clamp to hold the probe on a wall.
- Use the probe mounting flange to hold the probe in a through-wall installation.

NOTE

Avoid placing the probe in a place where condensation can run onto the sensor.

Probe Assembly with Duct Installation Kit

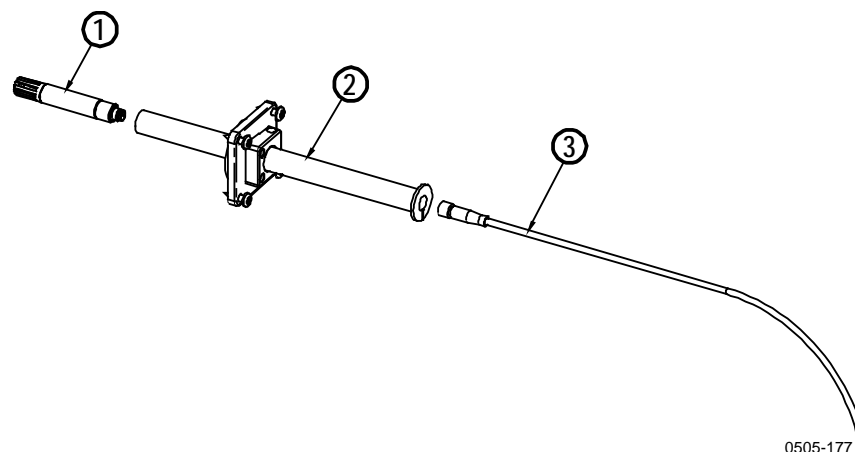

0505-177

Figure 18 Assembly of the Probe with Duct Installation Kit

The following numbers refer to Figure 18 above:

- 1 = HMP60, HMP110, HMP110D or HMP110T probe
- 2 = Duct installation kit
- 3 = Probe cable

1. Slide the probe cable through the duct installation kit plastic pipe.
2. Attach the cable to the probe.
3. Attach probe assembly to the duct.

Drilling Instructions for Duct Installation Kit

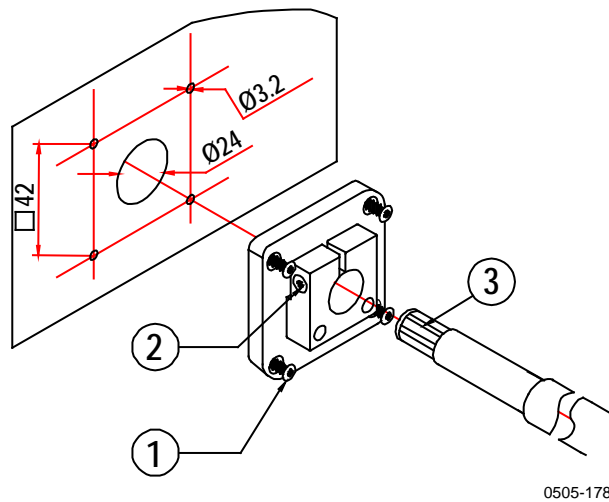

Figure 19 Drilling Instructions

The following numbers refer to Figure 19 above:

- 1 = Mounting screw
- 2 = Tension screw
- 3 = Probe assembled in duct installation kit plastic pipe

Drill the holes for the duct installation kit as follows:

1. Use a 24-mm drill bit to drill a hole to the duct wall for the humidity probe.
2. Drill holes for the duct installation kit mounting screws around the hole in a square arrangement, 42 mm apart from each other. Use a 3.2-mm drill bit to drill the holes for the mounting screws (four ST4.2×16-C-Z DIN 7981 screws).

Mounting the HMP63 and HMP113 Probes

HMP63 and HMP113 probes do not have a thread on the probe body. For a convenient installation, use the optional installation accessories:

- Use the probe mounting clamp to hold the probe on a wall.
- Use the probe mounting flange to hold the probe in a through-wall installation.
- If you are using the probe with a HMT120, HMT130, or HM40 hand-held meter, use the plastic locking bushing.

For information on these accessories, see section Installation Accessories (Optional) on page 14.

NOTE	Avoid placing the probe in a place where condensation can run onto the sensor.
-------------	--

Wiring

For a secure connection to the probe, connect to the 4-pin M8 connector using a threaded connector.

The grounding method depends on the probe and the installation type. See Table 4 below.

Table 4 Grounding Methods

Probe	Grounding method
HMP63 and HMP113	It is recommended to use a shielded cable and connect the shield to ground. In the shielded cables supplied by Vaisala, the threaded connector connects the shield to the probe housing.
HMP60, HMP110, HMP110D, HMP110T, HMP110REF	There are two ways to ground the probe depending on installation type. Choose only one of these ways: <ul style="list-style-type: none"> - Grounding is provided by the metal cover of the probe. If using shielded cables, shield is NOT connected to ground. - A shielded cable is used, and the shield is connected to ground. In the shielded cables supplied by Vaisala, the threaded connector connects the shield to the probe housing.

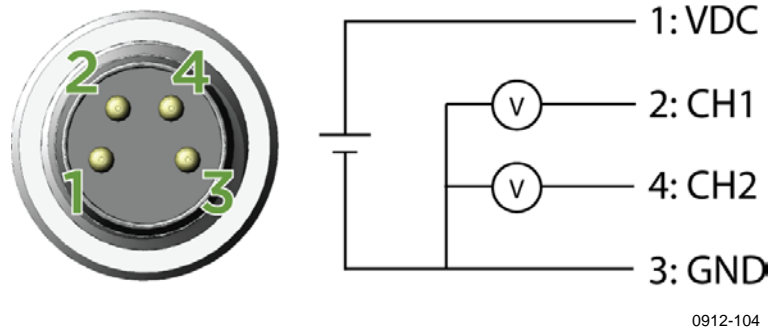

Figure 20 Wiring of Analog Output

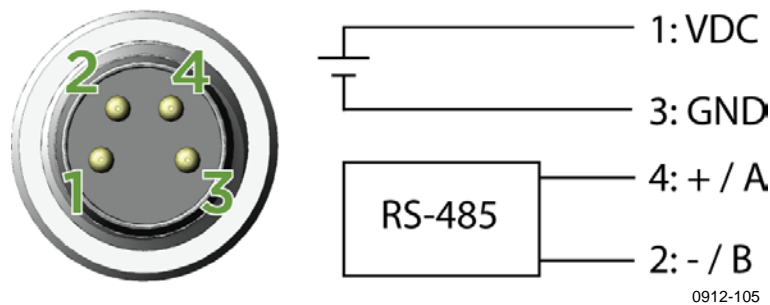

Figure 21 Wiring of Digital Output

Table 5 Pinout of the Probe Connector

Pin	HMP60 / HMP63 / HMP110 / HMP113 / HMP110T	HMP110D / HMP110REF	Wire color
1	5 ... 28 VDC (V_{out} 0 ... 1 / 0 ... 2.5 V) 8 ... 28 VDC (V_{out} 0 ... 5 / 1 ... 5 V)	5 ... 28 VDC	Brown
2	Channel 1: RH / Td / T 0 ... 1 / 2.5 / 5 V, 1 ... 5 V	RS485: - / B	White
3	GND / AGND	GND	Blue
4	Channel 2: RH / Td / T 0 ... 1 / 2.5 / 5 V, 1 ... 5 V *	RS485: + / A	Black

* HMP110T has no output on channel 2.

Wiring with the Loop Power Converter

To use the loop power converter module with a HMP60 or HMP110 series probe, make sure that:

- The probe is in the analog output mode
- The desired quantity must be on channel 1
- Channel 1 is scaled to 0 ... 2.5 V

The loop power converter cannot be used with HMP110D.

When using the loop power converter module, power the module with 8 ... 28 VDC. The operating voltage for the probe (5 VDC) is delivered by the module.

For more information, see the Loop Power Converter Quick Reference Guide.

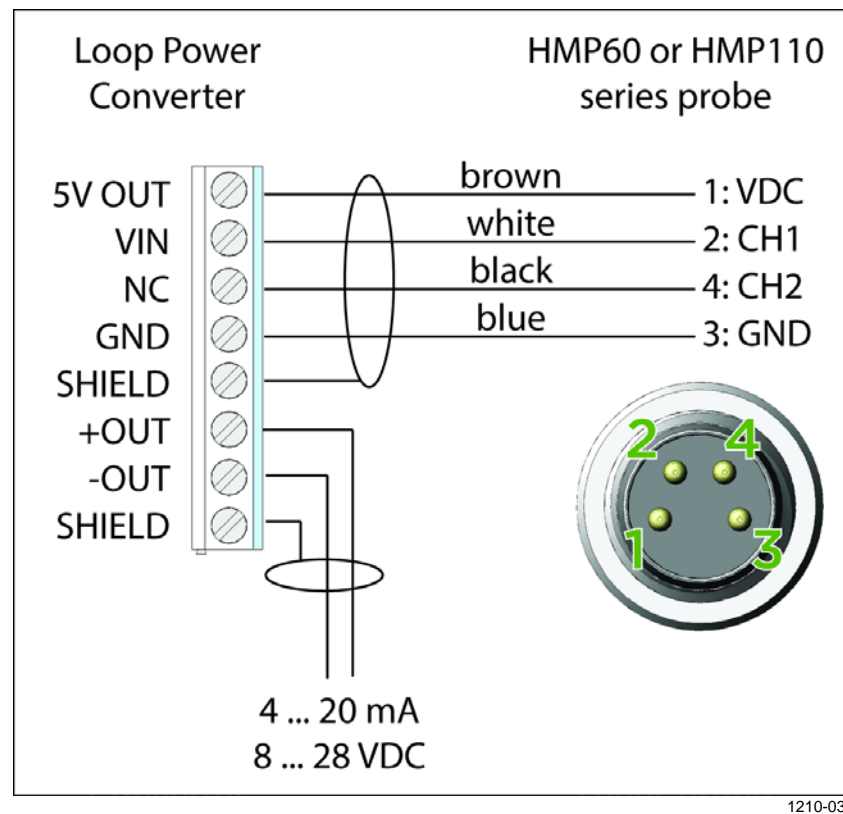

Figure 22 Wiring with the Loop Power Converter Module

Power Supply Requirements

The operating voltage for the HMP60 and HMP110 series probes must be in the following range:

Table 6 Operating Voltage Ranges

HMP60 / HMP63 / HMP110 / HMP113 / HMP110T	HMP110D / HMP110REF
5 ... 28 VDC (V_{out} 0 ... 1 / 0 ... 2.5 V)	5 ... 28 VDC
8 ... 28 VDC (V_{out} 0 ... 5 / 1 ... 5 V)	

Current consumption is 1 mA on average, which makes the probes well suited for running on battery power. The maximum peak consumption is 5 mA.

Recommendations

- Continuous use over high operating voltage may cause heating. To conserve power and minimize the warming of the probe, use the lowest operating voltage in the allowed range.
- Using low impedance loads on the signal outputs increase the current consumption by up to 0.5 mA. High impedance loads are recommended to minimize warming of the probe.
- Frequent interrogation of the probe using the RS-485 interface will also increase current consumption from the average value. More frequent interrogation than once per second is not recommended.

CHAPTER 4

OPERATION

This chapter contains information that is needed to operate the HMP60 and HMP110 series probes.

Getting Started

NOTE

Before you connect an HMP60 or HMP110 series probe to a device, it is recommended to power off the device.

When the probe is connected to a power supply, there is a delay as the probe starts up and the analog output stabilizes. The delay depends on the output type, and on the operating voltage that is supplied to the probe:

- Probes with analog output:
 - 4 s at operating voltage 13.5 ... 16.5 VDC
 - 2 s at other valid operating voltages
- Probes with digital output: 1 s

Serial Line Communication

NOTE

In analog probes, serial line communication is intended for service use only.

HMP60 and HMP110 series probes support two-wire RS-485 communication. The RS-485 interface is non-isolated and offers a maximum communications rate of 57600 bits/s.

There is no internal termination for the RS-485 on the probe. Use of termination resistors is not recommended. If the resistors are used, the possible increase in current consumption should be taken into account.

Connecting to the Serial Interface

The connection to the serial interface is via the 4-pin connector on the probe; see connector pinout on page 22.

For temporary use of the serial interface (for example, calibration), you can use the optional USB cable (Vaisala order code: 219690). Before you can use the USB cable, you must install the provided USB driver on your PC, see Installing the Driver for the USB Cable on page 30.

NOTE

The Vaisala USB cable is not designed for permanent installation. When using the USB cable, no separate power unit is needed. The probe is powered through the USB port.

For permanent interfacing to a host system, use a shielded cable with a threaded connector. See list of available cables in section Options and Accessories on page 72.

The probe does not echo typed characters back to the terminal screen. To see the commands you type, you need to enable the "local echo" setting in your terminal program.

A new command cannot be received while the probe is sending data out. Wait until the instrument has completed its response before entering the next command.

Table 7 Default Serial Communication Settings

Parameter	Value
Baud rate	19200
Parity	None
Data bits	8
Stop bits	1
Flow control	None

You can change the serial settings and operate in RUN, STOP, POLL and MODBUS modes.

After power-up the probe (in STOP mode) outputs the software version and the command prompt.

- In RUN mode, a measurement output starts immediately after power-up.
- In POLL mode, the probe does not output anything after power-up. It must be accessed with an addressed command.
- In MODBUS mode, the probe does not output anything after power-up: serial line commands are not in use and the probe must be used with the Modbus protocol. For instructions on returning to serial mode, see Accessing Serial Line Command Interface (RS-485 Mode) from Analog or Modbus Mode on page 34.

For a description of the modes and the SMODE command that is used to change the mode, see section Set Serial Interface Mode on page 41.

Installing the Driver for the USB Cable

Before taking the USB cable into use, you must install the provided USB driver on your PC. When installing the driver, you must acknowledge any security prompts that may appear.

1. Check that the USB cable is not connected. Disconnect the cable if you have already connected it.
2. Insert the media that came with the cable.
3. Execute the USB driver installation program (setup.exe), and accept the installation defaults. The installation of the driver may take several minutes.
4. After the driver has been installed, connect the USB cable to a USB port on your PC. Windows will detect the new device, and use the driver automatically.
5. The installation has reserved a COM port for the cable. Verify the port number, and the status of the cable, using the **Vaisala USB Instrument Finder** program that has been installed in the Windows Start menu. The reserved ports are also visible in the **Ports** section of the Windows Device Manager.

Remember to use the correct port in the settings of your terminal program. Windows will recognize each individual cable as a different device, and reserve a new COM port.

There is no reason to uninstall the driver for normal use. However, if you wish to remove the driver files and all Vaisala USB cable devices, you can do so by uninstalling the entry for **Vaisala USB Instrument Driver** from the **Programs and Features** menu in the Windows Control Panel. In Windows XP and earlier Windows versions the menu is called **Add or Remove Programs**.

Terminal Application Settings for Digital Probes

The steps below describe how to connect to digital probes using the PuTTY terminal application for Windows and the USB serial interface.

If you have an analog probe, you can still connect to the serial line by following the instructions in section Accessing Serial Line Command Interface (RS-485 Mode) from Analog or Modbus Mode on page 34.

1. Connect the USB serial interface cable between your PC and the probe.
2. Start the PuTTY application.
3. Select the **Serial** settings category, and check that the correct COM port is selected in the **Serial line to connect to** field.

You can check which port the USB cable is using with the **Vaisala USB Instrument Finder** program that has been installed in the Windows Start menu.

4. Check that the other serial settings are correct for your connection, and change if necessary. Refer to Table 7 on page 30 for the default serial line settings of the probe.
5. Click the **Open** button to open the connection window and start using the serial line.

If PuTTY is unable to open the serial port you selected, it will show you an error message instead. If this happens, restart PuTTY and check the settings.

6. You may need to adjust the **Local echo** setting in the **Terminal** category to see what you are typing on the serial line. To access the configuration screen while a session is running, click the right mouse button over the session window, and select **Change Settings...** from the pop-up menu.

If the probe is in Modbus mode, to access the serial port command interface, follow the instructions in Accessing Serial Line Command Interface (RS-485 Mode) from Analog or Modbus Mode on page 34.

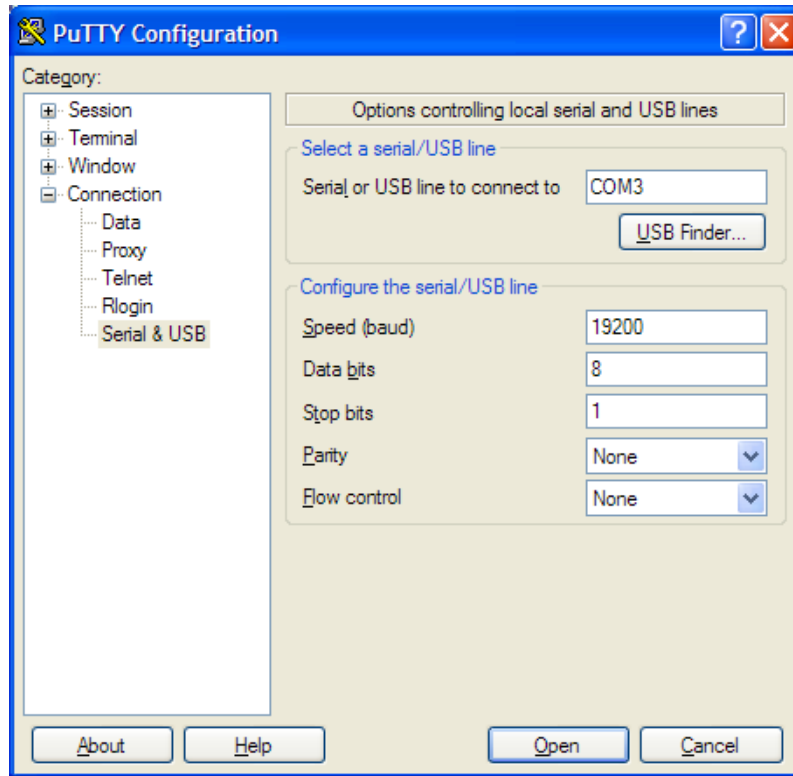

0807-004

Figure 23 PuTTY Terminal Application

Accessing Serial Line Command Interface (RS-485 Mode) from Analog or Modbus Mode

Follow the steps below to connect to the serial line when the probe is in analog or Modbus mode, or if you have entered incorrect communication settings, for example, with Modbus configuration registers and the settings need to be restored using the serial interface. You must use the Vaisala USB cable (Vaisala order code: 219690) in this case.

1. Connect the USB cable to the PC and install the driver, if necessary. Do not connect the cable to the probe yet.
2. Open the terminal program and open a connection to the corresponding COM port using the default settings 19200, 8, N, 1, no flow control.
3. Select the **Serial** settings category, and check that the correct COM port is selected in the **Serial line to connect to** field. You can check which port the USB cable is using with the **Vaisala USB Instrument Finder** program that has been installed in the Windows Start menu.
4. Click the **Open** button to open the connection window and start using the serial line.
5. Keep the **Enter** key pressed down and connect the other end of the USB cable to the probe. This will cause the probe to start in RS-485 mode, using the default serial settings. You can now use the probe with the terminal program (for information on available serial commands, see List of Serial Commands on page 36).
6. To prevent the analog or Modbus mode from being restored on the next power-up, select a different serial mode with the `smode` command (see Set Serial Interface Mode on page 41).
7. To switch back to analog mode or Modbus mode from the serial mode, use the `smode analog` command or the `smode modbus` command to select analog or Modbus mode. Reset or power cycle the probe to restart in the selected mode..

NOTE

The probe cannot be used with the MI70 hand-held indicator when the probe is in analog mode. To use the probe with MI70, enable the serial mode as instructed above.

Modbus Communication

The Modbus variant used in HMP60 and HMP110 series probes is Modbus RTU. For a list of the available Modbus registers, see Appendix A, Modbus Reference on page 73. The default communication settings used when Modbus is enabled at the factory (chosen when ordering) are listed in Table 8 below.

Table 8 Default Modbus Communication Settings

Setting	Default value (when Modbus is enabled at the factory)
Device address	240
Bit rate	19200
Number of data bits	8
Parity	N
Number of stop bits	2
Response delay	0
Communication mode	MODBUS

The communication settings can be changed with either serial line commands (see Table 9 below) or with the related Modbus configuration registers (see Table 17 on page 74).

If the device is already in Modbus mode, open the serial line interface as instructed in Accessing Serial Line Command Interface (RS-485 Mode) from Analog or Modbus Mode on page 34.

Table 9 Configuration Commands for Modbus RTU

Serial Command	Description
SMODE MODBUS	Enable Modbus communication protocol
SERl b p 8 s	Change baud rate and parity b = baud rate (9600, 19200, 38400, 57600) p = parity (E, N, or O) 8 = number of data bits must be 8 s = number of stop bits (2 if parity is N, 1 otherwise*) Bit rates less than 9600 b/s are not supported with Modbus.
ADDR a	Set Modbus address: a = new address (1...247)**
SDELAY d	Add extra Modbus response delay*** d = new delay in units of 1/250 seconds (0...255)

* Modbus specification defines that two stop bits must be used if parity is N.

** Addresses 248 ... 255 are not supported by the Modbus standard but work with HMP 60 and HMP110 series. Address 0 cannot be used on Modbus.

*** Extra response delay can be used, for example, to avoid problems caused by direction-switching delays in bus converters.

NOTE

The instrument must be switched off and on before the communication setting changes take effect.

List of Serial Commands

All commands can be issued either in uppercase or lowercase. In the command examples, the keyboard input by the user is in **bold** type.

The notation <cr> refers to pressing the carriage return (**Enter**) key on your computer keyboard. Press **Esc** to clear the command buffer before starting to enter commands.

Table 10 List of Serial Commands (software version 2.0.7)

Command	Description
?	Output information about the device
AERR	Set analog output error level
AMODE	View or set the analog output mode
AOVER [ON/OFF]	Allow analog outputs to exceed their range 10%
ASEL	Set analog output parameters and scaling
CDATE	View or set the calibration date
CODE	View the order code of the probe
CRH	Calibrate and adjust RH measurement
CRHCLR	Clear adjustment of RH measurement
CT	Calibrate and adjust T measurement
CTCLR	Clear adjustment of T measurement
CTEXT	View or set the calibration information field
ERRS	List present probe errors
FILT [0.001 ... 1]	Set the result filtering
FRESTORE	Restore factory settings
HELP	List available commands
INTV [0 ... 255 S/MIN/H]	Set the continuous output interval (for RUN mode)
L	Displays user adjustment parameters
R	Start the continuous outputting
RESET	Reset the probe
RHLIMIT	Extend maximum RH reading
S	Stop the continuous outputting
SDELAY [0 ... 255]	View or set serial line answer minimum delay
SEND [0 ... 255]	Output the reading once
SNUM	View the serial number of the probe
UNIT	Select metric or non-metric output units
VERS	View software version of the probe

Table 11 Additional Commands for Probes with RS-485 Output

Command	Description
??	Output information about the device in POLL mode
ADDR [0 ... 255]	Set the probe address (for POLL mode)
CLOSE	Close the temporary connection (Back to POLL mode)
OPEN [0 ... 255]	Open a temporary connection to a POLL mode device
SERI [baud p d s]	User Port settings (Default: 19200 N 8 1) baud: 300 ... 57600
SMODE [STOP/RUN/POLL/MODBUS/ VDIGI/ANALOG]	Set the serial interface mode

Device Information and Status

View Device Information

The ? command outputs a listing of device information.

?<cr>

Example (output from HMP63):

```
?
HMP63 / 1.0.4
Serial number   : H3640004
Batch number   : T0001109
Sensor number  : H0000322
Sensor model   : Intercap
Order code     : A12A0A2B0
Cal. date     : 20120907
Cal. info     : VAISALA/HEL
Time          : 00:21:05
Serial mode    : ANALOG
Baud P D S    : 19200 N 8 1
Output interval: 1 S
Serial delay   : 30
Analog delay  : 10 S
Address       : 0
Filter        : 1.000
Ch1 output    : 0 ... 1 V
Ch2 output    : 0 ... 1 V
Ch1 RH lo    : 0.00 %RH
Ch1 RH hi    : 100.00 %RH
Ch2 T lo     : -40.00 'C
Ch2 T hi     : 60.00 'C
```

If the probe is in poll mode, but a connection has not been opened using the **OPEN** command, issue the **??** command. For a description of the serial interface modes, see section Set Serial Line Settings on page 40.

??<cr>

View Calibration Information

Use the **CDATE** command to view the calibration date and **CTEXT** to view the calibration info text. Date format for **CDATE** is YYYYMMDD.

CDATE<cr>

CTEXT<cr>

Examples:

```
cdate  
Cal. date      : 20150109
```

```
ctext  
Cal. info      : VAISALA/HEL
```

Enter Calibration Information

To enter the calibration date, use the **CDATE** command (`cdate [YYYYMMDD]`). To enter a text string with information about the calibration, use the **CTEXT** command (`ctext [string]`).

CDATE [yyyymmdd] <cr>

CTEXT [text string] <cr>

Example:

```
cdate 20151125  
Cal. date      : 20151125  
ctext Calibrated in Room 1  
Cal. info      : Calibrated in Room 1
```

View Order Code

Use the **CODE** command to view the order code that has been stored in the probe. This command is useful if you need to order a new probe with the same options.

CODE<cr>

Example:

```
code  
Order code     : A12A0A2B0
```

View Serial Number

Use the **SNUM** command to view the serial number of the probe.

SNUM<cr>

Example:

```
snum  
Serial number : H3640004
```

View Software Version

Use the **VERS** command to display the software version of the probe.

VERS<cr>

Example:

```
vers  
HMP63 / 1.0.4
```

Serial Line Output Commands

Start Measurement Output

Use the **R** command to start the continuous outputting of measurement values as an ASCII text string to the serial line.

For HMP60, HMP110 and HMP110D, the output always includes readings for temperature, RH and Td. For HMP110T, the output includes only temperature.

R<cr>

Example (HMP60, HMP110 and HMP110D):

```
r  
T= 22.6 'C RH= 22.8 %RH Td= 0.3 'C  
T= 22.6 'C RH= 22.5 %RH Td= 0.2 'C  
T= 22.6 'C RH= 22.5 %RH Td= 0.2 'C  
...
```

Example (HMP110T):

```
r  
T= 22.6 'C  
T= 22.6 'C  
T= 22.6 'C  
...
```

Outputting the results continues in intervals issued with the command **INTV**. You can stop the output by entering the **S** command.

Stop Measurement Output

Use the **S** command or press the **Esc** key to stop the continuous measurement output.

S<cr>

Output the Measurement Message Once

Use the **SEND** command to output the measurement values once. If the probe is in **POLL** mode and the line is not open for commands, specify the address of the probe to receive the measurement message.

SEND [*aaa*]<cr>

where

aaa = Address of the probe, range 0 ... 255. Set with the **ADDR** command.

Example (probe in **STOP** mode, no address needed):

```
send  
T= 22.7 'C RH= 20.0 %RH Td= -1.5 'C
```

Example (probe in **POLL** mode, with address 10):

```
send 10  
T= 22.8 'C RH= 20.1 %RH Td= -1.3 'C
```

Configuring Serial Line Operation

Set Serial Line Settings

Use the **SERI** command to show or set the serial line settings. The new settings will be taken into use when the probe is reset or powered up.

SERI [*b p d s*]<cr>

where

b = baud rate
(300, 600, 1200, 2400, 4800, 9600, 19200, 38400, 57600)
p = parity (n = none, e = even, o = odd)
d = data bits (7 or 8)
s = stop bits (1 or 2)

Example (shows default settings):

```
seri
Baud P D S      :      19200 N 8 1
```

Set Serial Interface Mode

Use the **SMODE** command to set the operation mode of the serial interface. The new mode is applied when probe is reset.

```
SMODE [xxx]<cr>
```

where

xxx = Operation mode of the serial interface. See Table 12 below.

Table 12 Serial Interface Modes

Mode	Description
STOP	Probe outputs only when a command is issued. Any command can be used.
RUN	Probe automatically outputs measurement messages on the serial line. Only command S or the Esc key can be used to stop the output.
POLL	Probe outputs only when a command is issued. Probes communicate one at a time when the specific address is called on the serial line, which is useful when more than one probe is connected to one serial bus. Any command can be used after the line has been opened using the OPEN command. See descriptions of the commands ADDR on page 43 and OPEN on page 52.
MODBUS	Measurement outputs must be read from the transmitter using the Modbus protocol. For more information on Modbus, see Modbus Communication on page 35 and Appendix A, Modbus Reference on page 73.
VDIGI	Special serial interface mode that is only used for interoperability with Vaisala devices such as HMT120, HMT130, and HM40. This mode is set at Vaisala for probes that are ordered for such use.
ANALOG	No serial line, analog outputs active. For instructions on how to enter the serial line when in analog mode, see section Accessing Serial Line Command Interface (RS-485 Mode) from Analog or Modbus Mode on page 34.

Example (check current mode):

```
smode
Serial mode      :      STOP      ?
```

Example (change mode to POLL mode):

```
smode poll
Serial mode      :      POLL
```

NOTE

In the RUN mode, the probe may send the measurement data message right as you are typing the **S** command to stop the sending. Therefore, you may need to repeat the **S** command. This must be noted especially when designing computer programs to access the probe.

Set Output Interval

Use the **INTV** command to show or set the output interval of the serial line measurement messages (applies when **R** command or RUN mode is used). The shortest output interval is one second. This command has no effect on the operation of the analog output.

INTV [*n xxx*]
<cr>

where

n = Time interval in range 1 ... 255
xxx = time unit = "S", "MIN", or "H"

Example:

```
intv 1 s
Value           : 1
Unit            : S
```

Set Measurement Filtering

Use the **FILT** command to view or set the speed at which the latest measurement result is integrated into the humidity and temperature readings. The command affects both analog output and serial line output.

FILT [*a.aaa*]
<cr>

where

a.aaa = Range 0.001 ... 1.0.
 1.0 = No filtering, latest measurement is output without averaging
 0.5 = Average of last two measurements
 0.1 = Average of approximately 16 measurements

Example (default setting, no filtering):

```
filt
Filter           : 1.000 ?
```

Example (set filtering to 0.5):

```
filt 0.5
Filter           : 0.500
```

Set Probe Address

Use the **ADDR** command to view or set the probe address. To operate in the POLL mode, the probe must have an address. If multiple probes share the same serial line, each probe must have a different address.

For a description of the serial interface modes, see section Set Serial Line Settings on page 40.

```
ADDR [nn]<cr>
```

where

nn = address (0 ... 255)

Example:

```
addr  
Address : 0
```

Set Serial Interface Delay

Use the **SDELAY** command to view or set the serial interface answer minimum delay.

```
SDELAY [delay]<cr>
```

where

delay = Range 0 ... 255. Value corresponds to four milliseconds (for example, 5 = 0.020 second minimum answer delay)

Example:

```
sdelay  
Serial delay : 30  
  
sdelay 50  
Serial delay : 50
```

Set Measurement Units

Use the **UNIT** command to view or set the measurement units that are used in the serial line measurement messages.

UNIT [*M/N*]
<cr>

M is for metric units, N is for non-metric units.

Quantity	Metric Unit	Non-Metric Unit
RH	%RH	%RH
Td	°C	°F
T	°C	°F

Examples:

```
unit  
Units          : Metric
```

```
unit n  
Units          : Non metric
```

Calibration Commands

Calibrate Humidity Measurement

Use the **CRH** command to perform a one-point or two-point correction to the capacitance measurement of the probe. This command changes the offset and/or gain of the humidity measurement, depending on the calibration and reference:

- one-point calibration with a single < 50 %RH reference will adjust the offset of the capacitance measurement
- one-point calibration with a single > 50 %RH reference will adjust the gain of the capacitance measurement
- two-point calibration will adjust both offset and gain. The first point requires a < 50 %RH humidity reference, the second point must be > 50 %RH. There must also be at least 30 percentage point difference between the references.

CRH [reference]<cr>

This command is not available on the HMP110T.

When performing a one-point calibration, you need to place the probe in the reference humidity and wait for 20 – 40 minutes for the humidity to stabilize. To apply the adjustment, enter the **CRH** command with the reference %RH as a parameter.

Example: one-point calibration (LiCl reference, 11 %RH):

```
crh 11  
OK
```

Example: one-point calibration with NaCl reference (75 %RH):

```
crh 75  
OK
```

Giving the command without parameters starts the two-point calibration. Remember to allow the humidity to stabilize for 20 - 40 minutes after changing the reference.

Example: two-point calibration with LiCl (11 %RH) and NaCl (75 %RH) references:

```
crh  
RH : 11.2684 1. ref ? 11  
Press any key when ready ...  
RH : 75.0612 2. ref ? 75  
OK
```

Clear Adjustment of RH Measurement

Use the **CRHCLR** command to clear the adjustment of RH measurement that has been done using the **CRH** command. This command is not available on the HMP110T.

CRHCLR<cr>

Example:

```
crhclr
OK
```

Calibrate Temperature Measurement

Use the **CT** command to perform a one-point or two-point temperature (T) calibration. One-point calibration adjusts the offset for the measurement, two-point calibration adjusts offset and gain.

CT [reference]<cr>

When performing a one-point calibration, you need to place the probe in a single temperature reference and wait for 20 – 40 minutes for the temperature to stabilize. To apply the adjustment, enter the **CT** command with the reference temperature as a parameter.

Example: one-point calibration

```
ct 23.5
OK
```

Giving the command without parameters starts the two-point calibration. Remember to allow the temperature to stabilize for 20 - 40 minutes after changing the reference. The first reference point must be smaller than the second point, and the difference between the reference points must be more than 30 °C. To update the measured value while the command is running, press enter without inputting a value.

Example: two-point calibration

```
ct
T : 22.03 Ref1 ? 22
Press any key when ready ...
T : 55.12 Ref2 ? 55
OK
```

Clear Adjustment of T Measurement

Use the **CTCLR** command to clear the adjustment of temperature measurement that has been done using the **CT** command.

CTCLR<cr>

Example:

```
ctclr  
OK
```

View User Adjustment Parameters

Use the **L** command to view the current user adjustment parameters. This command is useful for checking the currently applied customer calibration.

L<cr>

The output values are as follows:

- Cp offset and gain: capacitance, calibrated using the **CRH** command
- T offset and gain: calibrated using the **CT** command

Example (shows default values, no user calibration done):

```
l  
Cp offset : 0.00000000E+00  
Cp gain   : 1.00000000E+00  
T  offset : 0.00000000E+00  
T  gain   : 1.00000000E+00
```

Other Commands

Set Analog Output Mode

Use the **AMODE** command to show or set the operation mode of the analog output. This command is not available on the HMP110D.

AMODE [*ch1*] [*ch2*]
<cr>

where

ch1 = Analog output mode for channel 1, range 0 ...3.

The options are:

0 (0 ... 1 V)

1 (0 ... 2.5 V)

2 (0 ... 5 V)

3 (1 ... 5 V)

ch2 = Analog output mode for channel 2, range 0 ...3.

The options are the same as for channel 1.

Example (show current output modes):

amode

Ch1 output : 0 ... 1 V

Ch2 output : 0 ... 1 V

Example (set channel 1 to 0 ... 1 V and channel 2 to 0 ... 5 V):

amode 0 2

Ch1 output : 0 ... 1 V

Ch2 output : 0 ... 5 V

Set Analog Output Parameters and Scaling

Use the **ASEL** command to show or set the output parameters and scaling of the analog outputs. This command is not available on the HMP110D.

ASEL [*ch1 ch2*] [*ch1low ch1high ch2low ch2high*]*<cr>*

where

- ch1** = Output parameter for channel 1. The options are:
 RH = Relative humidity
 TD = Dewpoint temperature
 T = Temperature
- ch2** = Output parameters for channel 2. The options are same as for channel 1.
- ch1low** = Low limit for channel 1 output scaling.
- ch1high** = High limit for channel 1 output scaling.
- ch2low** = Low limit for channel 2 output scaling.
- ch2high** = High limit for channel 2 output scaling.

Example (show current output parameters and scaling):

```

asel ?
Ch1 RH lo : 0.00 %RH ?
Ch1 RH hi : 100.00 %RH ?
Ch2 T lo : -20.00 'C ?
Ch2 T hi : 80.00 'C ?

```

Example (change channel 1 to output dewpoint temperature, adjust scaling to -40 ... 60 °C for channel 1 and to -20 ... 80 °C for channel 2):

```

asel td t -40 60 -20 80
Ch1 Td lo : -40.00 'C
Ch1 Td hi : 60.00 'C
Ch2 T lo : -20.00 'C
Ch2 T hi : 80.00 'C

```

Example (change channel 1 to output temperature and channel 2 to output relative humidity, adjust scaling for channel 1 to -40 ... 60 °C when prompted):

```

asel t rh
Ch1 T lo : -20.00 'C ? -40
Ch1 T hi : 80.00 'C ? 60
Ch2 RH lo : 0.00 %RH ?
Ch2 RH hi : 100.00 %RH ?

```

Set Analog Output Error Indication Level

If the device is malfunctioning, the analog output is set to a specified level. This overrides the normal measurement output of the channel. The default error level is 0 V, or another value predefined by the customer when ordering the device. You can set the level using the **AERR** command. This command is not available on the HMP110D.

AERR [*ch1 ch2*] <cr>

where

- ch1 = Error level of the analog output for channel 1. The available range depends on the output mode (check with **AMODE** command).
- ch2 = Error level of the analog output for channel 2. The available range depends on the output mode (check with **AMODE** command).

Example (show present output modes):

```
amode  
Ch1 output      : 0 ... 1 V  
Ch2 output      : 0 ... 1 V
```

Example (check present analog output error level):

```
aerr  
Ch1 error out: 0.000V ?  
Ch2 error out: 0.000V ?
```

Example (set analog output error level to 1 V on both channels):

```
aerr 1 1  
Ch1 error out: 1.000V ?  
Ch2 error out: 1.000V ?
```

NOTE

The error output value is displayed only when there are minor electrical faults such as humidity sensor damage. When there is a severe device malfunction, the error output value is not necessarily shown.

Extend Analog Output Range

Use the **AOVER** command to allow the analog output channels to exceed their specified range by 10%. The scaling of the quantity remains as before; the extra range is used for additional measurement range in the wet end. This command is not available on the HMP110D.

AOVER [*ON/OFF*]
<cr>

The following example illustrates how the analog output is affected. Channel 1 outputs T_d with voltage output 0 ... 5 V (-40 °C ... +60 °C). After giving the **AOVER ON** command, the range is 0 ... 5.5 V (-40 °C ... +70 °C). Note that the +60 °C T_d point is still at 5 V.

Example:

```
aover on
AOVER                :          ON
```

Extend Maximum RH Reading

With digital output, use the **RHLIMIT** command to set the maximum RH reading from 100% (default) up to 120%.

With analog output, the **RHLIMIT** command allows you to extend the high limit of the analog output scaling up to 120%. This command does not change the scaling automatically. To change the scaling, use the **ASEL** command (see Set Analog Output Parameters and Scaling on page 49).

RHLIMIT [*max_rh*]
<cr>

where

max_rh = Maximum reading of the RH parameter. The possible values are 100.0 ... 120.0. The default value is 100.0.

Example (extend the maximum RH reading to 120%):

```
rhlimit 120
Max. RH %      :      120.0 %RH
```

Example (on analog output, extend the maximum RH reading to 120% and scale the RH output on channel 2 from (0...1 V) 0...100% to (0...1 V) 0...120%):

```
rhlimit 120  
Max. RH %      :      120.0 %RH  
asel ?  
Ch1 T   lo    :   -20.00 'C ?  
Ch1 T   hi    :    80.00 'C ?  
Ch2 RH  lo    :    0.00 %RH ?  
Ch2 RH  hi    :   100.00 %RH ? 120
```

Display Command List

Use the **HELP** command to display a list of the currently available commands.

```
HELP<cr>
```

Display the Currently Active Errors

Use the **ERRS** command to display the currently active error codes. For troubleshooting active errors, see Table 13 on page 65.

```
ERRS<cr>
```

Example (no active errors):

```
errs  
0000h  
No errors
```

Connect to the Probe in POLL Mode

Use the **OPEN** command to connect to a probe that is in POLL mode.

```
OPEN [aa]<cr>
```

where

aa = address (0 ... 255)

Example:

```
open 1  
HMP110 1 line opened for operator commands
```

Close the Connection in POLL Mode

The **CLOSE** command closes the connection to the probe.

CLOSE<cr>

Example:

```
close
line closed
```

Reset the Probe

Use the **RESET** command to reset the probe. Upon reset or power-up, the probe enters the serial mode that has been set with the **S.MODE** command.

RESET<cr>

Example (probe set to serial mode STOP, will output probe model and software version at reset):

```
reset
HMP60 / 1.00.0
```

Example (probe set to serial mode RUN, will start to output measurement messages at reset):

```
reset
T= 23.6 'C RH= 20.2 %RH Td= -0.5 'C
T= 23.6 'C RH= 20.2 %RH Td= -0.5 'C
T= 23.3 'C RH= 20.2 %RH Td= -0.8 'C
...
```

Restore Factory Settings

Use the **FRESTORE** command to restore the factory settings to the probe. All user settings, including the user-performed calibration corrections, will be lost. The probe will revert back to the factory calibrated settings.

FRESTORE<cr>

Example:

```
frestore
Factory settings restored
```

CHAPTER 5

MAINTENANCE

This chapter provides information that is needed in basic maintenance of the HMP60 and HMP110 series probes.

Periodic Maintenance

The humidity measurement accuracy of the HMP60 and HMP110 series probes should be calibrated yearly. When calibration indicates that accuracy is not within specification:

- HMP60 and HMP63: change the INTERCAP® sensor.
- HMP110 and HMP113: adjust the measurement yourself, or have it adjusted at a Vaisala Service Center.

Light cleaning of the probe, and replacement of the filter should be done only when necessary.

Cleaning

The probe body can be wiped clean with a soft, lint-free cloth moistened with mild detergent. Do not use solvents or compressed air.

Note that wiping the membrane filter or stainless steel sintered filter may block its pores and/or deposit residue on the filter. If the filter is heavily contaminated, replace it.

Changing the Filter

The filter on the probe should be replaced when it is damaged or dirty.

1. Turn the filter counter-clockwise to loosen it.
2. Remove the filter from the probe. Be careful not to touch the sensors with the filter. Without the filter in place, the sensors are easily damaged – handle the probe carefully.
3. Install a new filter on the probe, and tighten it so it is finger-tight. Make sure the filter sits straight and meets the threads properly.

New filters can be ordered from Vaisala. For available filters, see section Filter Options on page 13. The order codes of the filters are listed in section Options and Accessories on page 72.

Calibration Procedure

To calibrate your probe, you need a known stable humidity or temperature reference, and a way to read the output of the probe (analog output, serial output, or the MI70 indicator). As a humidity reference you can use, for example, the Vaisala Humidity Calibrator HMK15.

NOTE

The probe cannot be used with the MI70 hand-held indicator when the probe is in analog mode. To use the probe with MI70, enable the serial mode as instructed in Accessing Serial Line Command Interface (RS-485 Mode) from Analog or Modbus Mode on page 34. To return to analog mode, use the `smode analog` serial line command (see Set Serial Interface Mode on page 41).

Refer to chapter Technical Data on page 67 for accuracy specifications of the probes.

1. Connect the power/signal cable or MI70 connection cable to the probe, but do not power it up yet.
2. Remove the filter from the probe and place the probe in the reference environment. For example, you can use a NaCl salt chamber (75 %RH) as the humidity reference.
3. Wait for 20 – 40 minutes for the reading to stabilize.
4. Power up the probe and wait for one minute.
5. Check the measurement reading, and compare it with the reading that the reference should produce.

Adjustment Procedure Using Serial Line (HMP110, HMP110D and HMP113)

NOTE

If you are adjusting a probe that is in the analog output mode, see section Accessing Serial Line Command Interface (RS-485 Mode) from Analog or Modbus Mode on page 34 for instructions on how to start the probe in RS-485 mode.

One-Point Adjustment of RH Measurement (HMP110, HMP110D and HMP113)

To perform a one-point adjustment to the capacitance measurement of the HMP110, HMP110D or HMP113 using serial line, you need:

- The Vaisala USB cable (Vaisala order code: 219690)
- PC with a terminal application.
- One humidity reference. One-point adjustment with a single < 50 %RH reference will adjust the *offset* parameter of the measurement. One-point adjustment with a single > 50 %RH reference will adjust the *gain* parameter of the measurement.

The procedure below uses the HMK15 Humidity Calibrator. LiCl salt (11 %RH) is used as the reference point.

1. Connect the USB cable to the PC, but do not connect it to the probe yet.
2. Remove the filter from the probe and insert the probe in the LiCl salt chamber of the humidity calibrator (11 %RH).
3. Start a terminal application and set the correct connection settings. The default serial settings are **19200 8 N 1**. Remember to check which COM port the USB cable is using.
4. Wait for 20 – 40 minutes for the humidity to stabilize.
5. Start the terminal session and connect the USB cable to the probe. If your probe is in the analog output mode, you need to press Enter a few times to start it in RS-485 mode.
6. Verify that the connection works by giving the ? command:

?

If the probe does not respond with device information:

- Disconnect the USB cable from the probe and retry. If your probe is in the analog output mode, press Enter a few times immediately after connecting the USB cable.

- Try the **??** command in case the probe is in POLL mode, open the line using **OPEN** command if necessary.
 - Check your serial line settings and cable connections.
7. When your serial connection is working, use the **L** command to see the current user adjustment parameters.

```
1
```

8. Use the **ERRS** command to see that no errors are active:

```
errs
```

9. Give the **CRH** command, with the %RH value of the reference as a parameter (in this case 11 for LiCl):

```
crh 11  
OK
```

10. Check with the **L** command that the user adjustment parameters have changed.

If you wish to remove the effects of RH calibration (returning the RH measurement of the probe to the factory calibrated state), see section Clear Adjustment of RH Measurement on page 46.

Two-Point Adjustment of RH Measurement (HMP110, HMP110D and HMP113)

To perform a two-point adjustment to the capacitance measurement of the HMP110, HMP110D or HMP113 using serial line you need:

- The Vaisala USB cable (Vaisala order code: 219690)
- PC with a terminal application.
- Two humidity references. The first point requires a < 50 %RH humidity reference, the second point must be > 50 %RH. There must also be at least 30 %RH difference between the references.

The procedure below uses the HMK15 Humidity Calibrator. LiCl salt (11 %RH) is used as the first reference point, NaCl (75 %RH) as the second.

1. Connect the USB cable to the PC, but do not connect it to the probe yet.
2. Remove the filter from the probe and insert the probe in the LiCl salt chamber of the humidity calibrator (11 %RH).
3. Start a terminal application and set the correct connection settings. The default serial settings are **19200 8 N 1**. Remember to check which COM port the USB cable is using.

4. Wait for 20 – 40 minutes for the humidity to stabilize.
5. Start the terminal session and connect the USB cable to the probe. If your probe is in the analog output mode, you need to press Enter a few times to start it in RS-485 mode.
6. Verify that the connection works by giving the **?** command:

?

If the probe does not respond with device information:

- Disconnect the USB cable from the probe and retry. If your probe is in the analog output mode, press Enter a few times immediately after connecting the USB cable.
 - Try the **??** command in case the probe is in POLL mode, open the line using **OPEN** command if necessary.
 - Check your serial line settings and cable connections.
7. When your serial connection is working, use the **L** command to see the current user adjustment parameters.

l

8. Use the **ERRS** command to see that no errors are active:

errs

9. Use the **SEND** command to verify the currently measured RH value:

send

T= 22.9 'C RH= 11.1 %RH Td= -8.0 'C

10. Give the **CRH** command with the RH value of the humidity reference as a parameter:

crh 11

OK

11. After entering the correction, unplug the USB cable from the probe. Insert the probe in the NaCl salt chamber (75 %RH) and wait for 20 – 40 minutes for humidity and temperature to stabilize.

12. Connect the USB cable to the probe and use the **SEND** command to see the currently measured value.

13. Give the **CRH** command with the RH value of the humidity reference as a parameter:

crh 75

OK

14. Check with the **L** command that the user adjustment parameters have changed.

If you wish to remove the effects of RH calibration (returning the RH measurement of the probe to the factory calibrated state), see section Clear Adjustment of RH Measurement on page 46.

One-Point Adjustment of T Measurement (HMP110, HMP110D, HMP113, and HMP110T)

To perform a one-point adjustment to the temperature measurement of the HMP110, HMP110D, HMP113, or HMP110T using serial line you need:

- The Vaisala USB cable (Vaisala order code: 219690)
 - PC with a terminal application.
 - One known and stable temperature reference.
1. Connect the USB cable to the PC, but do not connect it to the probe yet.
 2. Remove the filter from the probe and insert the probe in the temperature reference.
 3. Start a terminal application and set the correct connection settings. The default serial settings are **19200 8 N 1**. Remember to check which COM port the USB cable is using.
 4. Wait for 20 – 40 minutes for the temperature to stabilize.
 5. Start the terminal session and connect the USB cable to the probe. If your probe is in the analog output mode, you need to press Enter a few times to start it in RS-485 mode.
 6. Verify that the connection works by giving the **?** command:

?

If the probe does not respond with device information:

- Disconnect the USB cable from the probe and retry. If your probe is in the analog output mode, press Enter a few times immediately after connecting the USB cable.
 - Try the **??** command in case the probe is in POLL mode, open the line using **OPEN** command if necessary.
 - Check your serial line settings and cable connections.
7. When your serial connection is working, use the **L** command to see the current user adjustment parameters.

1

8. Use the **ERRS** command to see that no errors are active:

`errs`
9. Give the **CT** command, with the temperature value of the reference as a parameter:

`ct 23.5`
`OK`
10. Check with the **L** command that the user adjustment parameters have changed.

If you wish to remove the effects of T calibration (returning the T measurement of the probe to the factory calibrated state), see section Clear Adjustment of T Measurement on page 47.

Adjustment Procedure Using MI70 Indicator (HMP110, HMP110D and HMP113)

NOTE

The probe cannot be used with the MI70 hand-held indicator when the probe is in analog mode. To use the probe with MI70, enable the serial mode as instructed in Accessing Serial Line Command Interface (RS-485 Mode) from Analog or Modbus Mode on page 34. To return to analog mode, use the `smode analog` serial line command (see Set Serial Interface Mode on page 41).

One-Point Adjustment of RH Measurement (HMP110, HMP110D and HMP113)

NOTE

If you want to perform a two-point adjustment instead of a one-point adjustment, use the serial line. See Two-Point Adjustment of RH Measurement (HMP110, HMP110D and HMP113) on page 57.

To perform a one-point adjustment to the capacitance measurement of the HMP110, HMP110D or HMP113 using the MI70 indicator, you need:

- MI70 indicator.
- Connection cable for MI70 indicator (219980).
- One humidity reference. One-point adjustment with a single < 50 %RH reference will adjust the *offset* parameter of the measurement. One-point adjustment with a single > 50 %RH reference will adjust the *gain* parameter of the measurement.

The procedure below uses the HMK15 Humidity Calibrator. LiCl salt (11 %RH) is used as the reference point.

1. Connect the probe to Port I of the MI70 indicator.
2. Turn on the MI70 indicator.
3. Start the adjustment sequence from **Main menu > Functions > Adjustments**.
4. MI70 notifies you that automatic power off is disabled during adjustment mode, press **OK** to acknowledge.
5. Select the **RH** parameter when prompted.
6. Now the adjustment mode is on, press **ADJUST** to select the adjustment method.
7. Select **1-point adjustment**, press **SELECT**. Press **OK** to continue.
8. Insert the probe in the LiCl salt chamber of the humidity calibrator (11 %RH).
You can follow the stabilization from the **GRAPH** display. Press **READY** when the reading is stabilized.
9. Give the reference humidity value by using the arrow buttons. Press **OK**.
10. Confirm the adjustment, press **YES** (by pressing **NO** you return to adjustment mode display and no changes are made).
11. Adjustment has been carried out. Press **BACK** to exit the adjustment mode, and press **EXIT** to return to the basic display.

One-Point Adjustment of Temperature Measurement

Temperature adjustment can be done if there is reason to believe that the adjustment is changed. In a 1-point adjustment, make sure the reference condition represents the measuring environment.

To perform a one-point adjustment to the temperature measurement of the HMP110, HMP110D or HMP113 using the MI70 indicator, you need:

- MI70 indicator.
- Connection cable for MI70 indicator (219980).

- One known and stable temperature reference.
- 1. Connect the probe to Port I of the MI70 indicator.
- 2. Turn on the MI70 indicator.
- 3. Start the adjustment sequence from **Main menu > Functions > Adjustments**.
- 4. MI70 notifies you that automatic power off is disabled during adjustment mode, press **OK** to acknowledge.
- 5. Select the **T** parameter when prompted.
- 6. Now the adjustment mode is on, press **ADJUST** to select the adjustment method.
- 7. Select **1-point adjustment**, press **SELECT**.
- 8. Set the probe to a reference temperature. You can follow the stabilization from the **GRAPH** display. Press **READY** when the reading is stabilized in the reference.
- 9. Give the reference temperature value by using the arrow buttons. Press **OK**.
- 10. Confirm the adjustment, press **YES** (by pressing **NO** you return to adjustment mode display and no changes are made).
- 11. Calibration is carried out. Press **BACK** to exit the adjustment mode and **EXIT** to return to the basic display.

Repair Maintenance

Changing the INTERCAP® Sensor (HMP60 and HMP63)

This procedure restores the humidity measurement accuracy of the probe. No adjustment after the sensor change is needed.

To perform this procedure, you need a new INTERCAP® sensor. It is also recommended that you replace the filter with a new one. For order codes, see section Options and Accessories on page 72.

1. Remove the filter from the probe by turning it counter-clockwise.
2. There are two sensors under the filter, the INTERCAP® sensor and a temperature sensor. Identify the INTERCAP® sensor – do not touch the temperature sensor.



1210-035

Figure 24 INTERCAP® Sensor

3. Pull out the old INTERCAP® sensor and insert a new one. Refer to Figure 25 below. Handle the new sensor by the plastic frame. **DO NOT TOUCH THE SENSOR PLATE.**



1210-034

Figure 25 Removing the Sensor

4. Attach a new filter on the probe.

Changing the HUMICAP® 180R Sensor (HMP110, HMP110D and HMP113)

NOTE

Replacing the humidity sensor of the HMP110, HMP110D and HMP113 is not necessary in normal operation. If the accuracy of the probe does not seem to be within specification, it is likely that the accuracy can be restored by performing the adjustment procedure. See section Two-Point Adjustment of RH Measurement (HMP110, HMP110D and HMP113) on page 57.

Follow this procedure to replace the humidity sensor of the HMP110, HMP110D and HMP113 in case it has been damaged, or normal adjustment is not sufficient to restore the measurement accuracy. Calibration and adjustment of the humidity measurement is required after the sensor change.

To perform this procedure, you need a new HUMICAP® 180R sensor. It is also recommended that you replace the filter with a new one. For order codes, see section Options and Accessories on page 72.

1. Remove the filter from the probe by turning it counter-clockwise.
2. There are two sensors under the filter, the HUMICAP® sensor and a temperature sensor. Identify the HUMICAP® sensor – do not touch the temperature sensor.

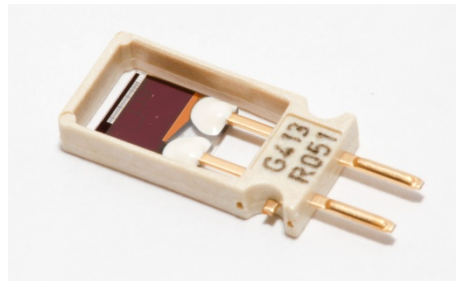

1210-035

Figure 26 HUMICAP® 180R Sensor

3. Pull out the old HUMICAP® 180R sensor and insert a new one. Refer to Figure 25 on page 63. Handle the new sensor by the plastic frame. **DO NOT TOUCH THE SENSOR PLATE.**
4. Perform a two-point adjustment of the RH measurement as instructed in section Two-Point Adjustment of RH Measurement (HMP110, HMP110D and HMP113) on page 57.
5. Attach a new filter on the probe.

CHAPTER 6

TROUBLESHOOTING

This chapter describes common problems, their probable causes and remedies, and contact information for technical support.

Analog Output Error Notification

If the device is unable to measure due to an error, the analog output will be set to an error level. The default error level is 0 V, or another value predefined by the customer when ordering the device.

You can change the analog output error level using the AERR command, see section Set Analog Output Error Indication Level on page 50.

Solving Typical Problems

You can check the error message via the serial interface by using the **ERRS** command. If you are unable to remove the errors, contact Vaisala technical support. See section Technical Support on page 66.

Table 13 Troubleshooting Table

Problem or Message	Likely Causes and Solutions
Measurement not working. any of the following errors active: - T meas error - RH meas error	<ul style="list-style-type: none"> - Sensor(s) damaged or missing. Open the filter and check. - Check the supply voltage of the probe. - Check the output mode of the probe using serial line.
Humidity measurement appears to be wrong.	<ul style="list-style-type: none"> - Check for condensation on the probe and sensor. - Use the L command to check the currently applied calibration correction. - Calibrate and adjust the probe (HMP110). - Calibrate the probe and change the sensor if necessary (HMP60).

Problem or Message	Likely Causes and Solutions
The probe is not responding to any serial commands.	<ul style="list-style-type: none"> - Disconnect the USB cable from the probe and retry. If your probe is in the analog output mode, press ENTER a few times immediately after connecting the USB cable. - Try the ?? command in case the probe is in POLL mode, open the line using OPEN command if necessary. - Check your serial line settings and cable connections.
The following error is active: - Voltage error	- Operating voltage out of range. Correct voltage and reset probe.
Any check sum error is active. For example: - Program flash check sum error - Parameter flash check sum error	Internal error. Perform the following steps: 1. Return the probe to factory settings using the FRESTORE command. Check again. 2. If the error is still active, contact Vaisala technical support.
The following error is active: - Frequency measurement outside the permissible value range	<ul style="list-style-type: none"> - Check for condensation on the probe and sensor. Allow the probe and sensor to dry. <p>If the error is still active, there may be a problem with the electronics. Contact Vaisala technical support.</p>

Technical Support

- Name and model of the product in question
- Serial number of the product
- Name and location of the installation site
- Name and contact information of a technically competent person who can provide further information on the problem.

CHAPTER 7

TECHNICAL DATA

This chapter provides the technical data of the HMP60 and HMP110 series probes.

Specifications

Performance (HMP60 and HMP63)

Relative Humidity

Measurement range	0 ... 100 %RH
Typical accuracy	
temperature range +0 ... +40 °C	
0 ... 90 %RH	±3 %RH
90 ... 100 %RH	±5 %RH
temperature range -40 ... 0 °C	
and +40 ... +60 °C	
0 ... 90 %RH	±5 %RH
90 ... 100 %RH	±7 %RH
Humidity sensor	Vaisala INTERCAP®

Temperature

Measurement range	-40 ... +60 °C
Accuracy over temperature range	
+10 ... +30 °C	±0.5 °C
-40 ... +60 °C	±0.6 °C

Dewpoint

Measurement range	-40 ... +60 °C
Typical accuracy	
temperature range 0 ... +40 °C	
when dewpoint depression* < 15 °C	±2 °C
temperature range -40 ... 0 °C	
and +40 ... +60 °C when	
dewpoint depression* < 10 °C	±3 °C

*dewpoint depression = ambient temperature - dewpoint

Performance (HMP110 and HMP110D)

Relative Humidity

Measurement range	0 ... 100 %RH
Accuracy (incl. non-linearity, hysteresis and repeatability)	
temperature range +0 ... +40 °C	
0 ... 90 %RH	±1.5 %RH
90 ... 100 %RH	±2.5 %RH
temperature range -40 ... 0 °C and +40 ... +80 °C	
0 ... 90 %RH	±3.0 %RH
90 ... 100 %RH	±4.0 %RH
Factory calibration uncertainty (+20 °C)	0 ... 90%RH ±1.1 %RH 90 ... 100%RH ±1.8 %RH
Humidity sensor	Vaisala HUMICAP® 180R
Stability	±2 %RH over 2 years
Response time (t90)	
with plastic grid filter	approx. 17 s
with membrane filter	approx. 20 s
with stainless steel sintered filter	approx. 60 s

Temperature

Measurement range	-40 ... +80 °C
Accuracy over temperature range	
0 ... +40 °C	±0.2 °C
-40 ... 0 °C, +40 ... +80 °C	±0.4 °C
Factory calibration uncertainty	±0.2 °C
Temperature sensor	Pt1000 RTD Class F0.1 IEC 60751

Dewpoint

Measurement range	-40 ... +80 °C
Accuracy (incl. non-linearity, hysteresis and repeatability)	
temperature range 0 ... +40 °C	
when dewpoint depression < 15 °C	±1 °C
when dewpoint depression 15 ... 25 °C	±2 °C
temperature range -40 ... 0 °C and +40 ... +80 °C when dewpoint depression < 15 °C	±2 °C

Performance (HMP113)

Relative Humidity

Measurement range	0 ... 100 %RH
Accuracy (incl. non-linearity, hysteresis and repeatability)	
temperature range +0 ... +40 °C	
0 ... 90 %RH	±1.5 %RH
90 ... 100 %RH	±2.5 %RH
temperature range -40 ... 0 °C and +40 ... +60 °C	
0 ... 90 %RH	±3.0 %RH
90 ... 100 %RH	±4.0 %RH
Factory calibration uncertainty (+20 °C)	±1.5 %RH
Humidity sensor	Vaisala HUMICAP® 180R
Stability	±2 %RH over 2 years

Temperature

Measurement range	-40 ... +60 °C
Accuracy over temperature range	
0 ... +40 °C	±0.2 °C
-40 ... 0 °C, +40 ... +60 °C	±0.4 °C
Factory calibration uncertainty	±0.2 °C
Temperature sensor	Pt1000 RTD Class F0.1 IEC 60751

Dewpoint

Measurement range	-40 ... +60 °C
Accuracy (incl. non-linearity, hysteresis and repeatability)	
temperature range 0 ... +40 °C	
when dewpoint depression < 15 °C	±1 °C
when dewpoint depression 15 ... 25 °C	±2 °C
temperature range -40 ... 0 °C and +40 ... +60 °C when dewpoint depression < 15 °C	±2 °C

Performance (HMP110T)

Temperature

Measurement range	-40 ... +80 °C
Accuracy over temperature range	
0 ... +40 °C	±0.2 °C
-40 ... 0 °C, +40 ... +80 °C	±0.4 °C
Factory calibration uncertainty	±0.2 °C
Temperature sensor	Pt1000 RTD Class F0.1 IEC 60751

Operating Environment

Operating temperature range	
HMP60	-40 ... +60 °C
HMP63	-40 ... +60 °C
HMP110	-40 ... +80 °C
HMP113	-40 ... +60 °C
HMP110D	-40 ... +80 °C
HMP110T	-40 ... +80 °C
Operating humidity range	0 ... 100 %RH, non-condensing
Electromagnetic compatibility	
HMP60, HMP110, HMP110D and HMP110T	EN 61326-1: Electrical equipment for measurement, control and laboratory use - EMC requirements – for use in industrial locations. EN 55022 Class B: Information technology equipment - Radio disturbance characteristics - Limits and methods of measurement.
HMP63 and HMP113	EN 61326-1: Electrical equipment for measurement, control and laboratory use - EMC requirements – Basic immunity test requirements. EN 55022 Class B: Information technology equipment - Radio disturbance characteristics - Limits and methods of measurement.

Inputs and Outputs

Operating voltage	
with 0...1 V / 2.5 V or RS-485	5 ... 28 V
with 0...5 V / 1 ... 5 V	8 ... 28 V
Current consumption	
typical average	1 mA
max peak	5 mA
Start-up time	
probes with analog output	4 s at operating voltage 13.5 ... 16.5 VDC 2 s at other valid operating voltages
probes with digital output	1 s
Outputs	
HMP60, HMP63, HMP110, HMP113 and HMP110T	
analog output channels	2
analog output types	0 ... 1 VDC / 2.5 VDC / 5VDC, 1 ... 5 VDC
with loop power converter	4 ... 20 mA (separate module, compatible with humidity accuracy only)
digital output (for service use)	RS-485 two-wire half-duplex
HMP110D	
digital output	RS-485 two-wire half-duplex

External loads	
0 ... 1	R_L min 10 k Ω
0 ... 2.5 / 0 ... 5 / 1 ... 5 V	R_L min 50 k Ω

Mechanics (HMP60, HMP110, HMP110D and HMP110T)

Materials	
body	Stainless steel (AISI 316)
grid filter	Chrome coated ABS plastic
cable	Polyurethane or FEP
Housing classification	IP65
Body thread	M12x1 / 10 mm
Cable connector	4-pin M8 (IEC 60947-5-2)
Cable lengths	0.3 and 3 m
Weight	
probe	17 g
probe with 0.3 m cable	28 g

Mechanics (HMP63 and HMP113)

Materials	
body	PC/ABS blend
grid filter	PC (glass reinforced)
cable	Polyurethane or FEP
Housing classification	IP54
Cable connector	4-pin M8 (IEC 60947-5-2)
Cable lengths	0.3 and 3 m
Weight	
probe	9 g
probe with 0.3 m cable	20 g

Options and Accessories

Table 14 Options and Accessories

Description	HMP60	HMP110	HMP110D	HMP110T	HMP63	HMP113	Item Code
Sensors							
Vaisala INTERCAP® sensor, 1 piece	•				•		15778HM
Vaisala INTERCAP® sensor, 10 pcs	•				•		INTERCAPSET-10PCS
Vaisala HUMICAP® 180R sensor		•	•			•	HUMICAP180R
Sensor protection							
Plastic grid filter, male thread	•	•	•	•			DRW010522
Membrane filter, male thread	•	•	•	•			DRW010525
Stainless steel sintered filter, male thread	•	•	•	•			HM46670SP
Plastic grid for use with HM40, male thread					•	•	DRW236214SP
Membrane filter, female thread					•	•	230727SP
Stainless steel sintered filter, female thread					•	•	HM47280SP
Porous PTFE filter, female thread					•	•	219452SP
Accessories							
Loop power converter (4 ... 20 mA)	•	•		•	•	•	UI-CONVERTER-1CB
Mounting bracket with lid for loop power converter	•	•	•	•	•	•	225979
Plastic M12 installation nuts, pair	•	•	•	•			18350SP
Probe mounting clamp set, 10 pcs	•	•	•	•	•	•	226067
Probe mounting flange	•	•	•	•	•	•	226061
Duct installation kit	•	•	•	•			215619
Plastic locking bushing (3 pcs)					•	•	DRW238590SP
USB serial interface cable	•	•	•	•	•	•	219690

• = Part is compatible

Table 15 Connection Cables

Description	Item Code
Standard 0.3 m	HMP50Z032SP
Standard 1.2 m	HMP50Z120SP
Standard 3 m	HMP50Z300SP
80 °C 1.5 m	225777SP
80 °C 3 m	225229SP
1.5 m FEP	238025SP
+180 °C 3 m FEP	226902SP
Connection cable for MI70	219980

APPENDIX A

MODBUS REFERENCE

This appendix describes the Modbus protocol implementation of the HMP60/HMP110 series probes. For information on Modbus communication and instructions on accessing Modbus mode and configuring the communication settings, see Modbus Communication on page 35.

- Supported Modbus functions are described in Table 16 below.
- Supported measurement and configuration registers are described in Table 17 on page 74.
- Device identification objects are described in Table 18 on page 76.
- Communication test registers are described in Table 19 on page 76.

Supported Modbus Functions

Table 16 below lists the function codes supported in the HMP60/HMP110 series Modbus RTU implementation.

Table 16 Supported Function Codes

Function Code (decimal)	Function Code (hexadecimal)	Function Name (as defined by the specification)	Notes
3	03	Read Holding Registers	See Table 17 on page 74 for available registers.
16	10	Write Multiple Registers	See Table 17 on page 74 for available registers.
43 14	2B 0E	Read Device Identification	See Table 18 on page 76 for available device identification objects.

NOTE

After power-up, wait for two seconds before sending Modbus requests.

Modbus Register Map

Table 17 Modbus Register Map (Measurement Values and Settings)

Logical Address (decimal)	PDU Address (hexadecimal)	Register Description	Data Format	Register Type	Notes
1	00 00	RH (measured) * LSW MSW	32-bit float	read-only	%
2	00 01				
3	00 02	T (measured) LSW MSW	32-bit float	read-only	°C
4	00 03				
9	00 08	T _d (measured) * LSW MSW	32-bit float	read-only	°C
10	00 09				
513	02 00	Fault status	16-bit integer	read-only	1 = no errors
516	02 03	Error code LSW MSW	32-bit bit field	read-only	
517	02 04				
518	02 05	Security hash LSW MSW	32-bit integer	read-only	Security hash changes on any change to device settings or adjustments
519	02 06				
785	03 10	Filtering (set value) LSW MSW	32-bit float	read/write	0.001 (maximum filtering) ... 1.000 (no filtering).
786	03 11				
1537	06 00	Address	16-bit integer	read/write	0...255 (only 1...247 recommended on Modbus)
1538	06 01	Bit rate (b/s) **	16-bit integer	read/write	0=300, 1=600, 2=1200, 3=2400, 4=4800, 5=9600, 6=19200, 7=38400, 8=57600
1539	06 02	Parity, data, stop bits **	16-bit integer	read/write	0=N81, 1=N82, 2=E81, 3=E82, 4=O81, 5=O82, 8=N71, 9=N72, 10=E71, 11=E72, 12=O71, 13=O72
1540	06 03	Response delay	16-bit integer	read/write	0...1020 ms
1541	06 04	Protocol **	16-bit integer	read/write	0=Command line (STOP), 1=Automatic output (RUN), 2=Polled output (POLL), 5=Analog outputs, 6=Modbus RTU
1542	06 05	Restart device	16-bit integer	write-only	Write 1 to restart device

* Availability of the register depends on the device model.

** Changed setting will be activated on device restart.

PDU address	Actual address bytes used in a Modbus Protocol Data unit.
LSW	Least significant word (bits 15 ... 0).
MSW	Most significant word (bits 31 ... 16).
16-bit integer	Numeric value in range -32768 ... +32767.
32-bit bit field	32 individual values, each 0 or 1.
32-bit integer	Numeric value in range -2147483648...+2147483647.
32-bit float	Floating point number encoded in IEEE 754 "binary32" format.
N-byte string	Text up to N-1 characters with 0-byte(s) at the end.
read-only	Register value cannot be changed with Modbus functions.
read/write	Register value can be changed with Modbus functions.
write-only	Register value can be written but is always read as zero.

Modbus RTU requires 8 data bits and is supported only at bit rates 9600 b/s and above. Modbus RTU specification recommends N82, E81, or O81 only.

A complete 32-bit value (two Modbus registers) must be read and written in a single Modbus transaction.

A “quiet NaN” value is returned for unavailable floating-point values (e.g. in case of measurement error). Several registers may be read in one transaction, even if there are gaps in the register map. Registers not listed contain typically value NaN or 0.

NOTE

If incompatible settings/protocol are selected and the probe is then restarted, it might no longer be possible to communicate with the probe using Modbus. If needed, you can override invalid communication settings configured in Modbus mode by switching to the serial line mode as instructed in Accessing Serial Line Command Interface (RS-485 Mode) from Analog or Modbus Mode on page 34 and entering correct settings with serial line commands.

Device Identification Objects

Table 18 Device Identification Objects

Object Id (decimal)	Object Id (hexadecimal)	Object Name (as defined by the specification)	Example
0	00	VendorName	Vaisala
1	01	ProductCode	HMP110
2	02	MajorMinorVersion	2.1.0
3	03	VendorUrl	http://www.vaisala.com
4	04	ProductName	Vaisala HUMICAP® Humidity and Temperature Probe HMP110
128	80	SerialNumber*	D0710040
129	81	CalibrationDate*	2015-11-21
130	82	CalibrationText*	Vaisala/HEL

*Vaisala-specific device information object

NOTE

Both stream access and individual access to the device identification objects are supported.

Communication Test Registers

Communication test registers can be used to find the correct Modbus master configuration for the data types and the byte order of the Vaisala device.

Test registers are also useful for testing if the register addresses should be specified as 1-based logical or 0-based PDU addresses on the master.

Table 19 Communication Test Registers

Logical Address (decimal)	PDU Address (hexadecimal)	Register Description	Data Format	Register Type	Notes
7937	1F 00	Test value (signed integer)	16-bit integer	read-only	Constant value -123.45×100 (CFC7 _h)
7938	1F 01	Test value (floating point) LSW MSW	32-bit bit float	read-only	Constant value -123.45 (C2F6 E666 _h)
7939	1F 02				
7940	1F 03	Test value (text string)	8-byte string	read-only	Constant text "-123.45" (2D31 3233 2E34 3500 _h)
7941	1F 04				
7942	1F 05				
7943	1F 06				

上海博众测量技术有限公司

Bodhi (Shanghai) measurement technology Co.,Ltd.
NO.32,ShuPing Road, JiadingDistrict,ZIP201808,
Shanghai R.P.China

TEL: 0086 21 6630 8161/62/63

FAX: 0086 21 6630 8167

www.bodhi-mt.com